



HAL
open science

Towards Multi-Spectral Hole Probing in Laser Frequency Stabilization

M. T. Hartman, S. Zhang, X. Lin, N Lučić, N. Galland, R. Le Targat, B.
Fang, Y. Le Coq, A. Ferrier, P. Goldner, et al.

► **To cite this version:**

M. T. Hartman, S. Zhang, X. Lin, N Lučić, N. Galland, et al.. Towards Multi-Spectral Hole Probing in Laser Frequency Stabilization. 2022 Joint Conference of the European Frequency and Time Forum and IEEE International Frequency Control Symposium (EFTF/IFCS), Apr 2022, Paris, France. pp.1-3, 10.1109/EFTF/IFCS54560.2022.9850914 . obspm-04030185

HAL Id: obspm-04030185

<https://hal-obspm.ccsd.cnrs.fr/obspm-04030185v1>

Submitted on 11 Oct 2023

HAL is a multi-disciplinary open access archive for the deposit and dissemination of scientific research documents, whether they are published or not. The documents may come from teaching and research institutions in France or abroad, or from public or private research centers.

L'archive ouverte pluridisciplinaire **HAL**, est destinée au dépôt et à la diffusion de documents scientifiques de niveau recherche, publiés ou non, émanant des établissements d'enseignement et de recherche français ou étrangers, des laboratoires publics ou privés.

Towards Multi-Spectral Hole Probing in Laser Frequency Stabilization

M. T. Hartman, S. Zhang, X. Lin,
N. Lučić, N. Galland, R. Le Targat,
B. Fang, Y. Le Coq
*LNE-SYRTE, Observatoire de Paris
Université PSL, CNRS, Sorbonne Université
Paris, France
michael.hartman@obspm.fr*

A. Ferrier, P. Goldner
*Institut de Recherche de Chimie Paris
Université PSL, Chimie ParisTech, CNRS
Paris, France*

S. Seidelin
*Grenoble INP and Institut Néel
Université Grenoble Alpes, CNRS
Grenoble, France*

Abstract—We report on the status of improvements to Spectral Hole Burning (SHB) laser stabilization experiment at SYRTE. Current efforts are toward the development of a novel multi-spectral-hole sensing scheme and preparations for the installation of a dilution cryogenic stage to cool the spectroscopic crystal to below 1 K.

Index Terms—Spectral Hole Burning, Laser Frequency Stabilization, Metrology

I. INTRODUCTION

Ultra frequency stabilized lasers provide the probe in the measurement of optical transitions for optical atomic clocks. Currently, the state of the art in laser frequency stabilization utilize ultra-length-stable optical cavities as a frequency reference [1] [2]. These references are reaching their fundamental limit as the community demonstrates laser frequency stabilities at the limit of the internal thermal noise of the optical cavities, prompting us to explore new topologies in frequency stabilization. At SYRTE, we explore the use of a spectral pattern imprinted in a rare-earth-ion doped crystal ($\text{Eu}^{3+}:\text{Y}_2\text{SiO}_5$) as a frequency reference in a process known as Spectral Hole Burning (SHB), a promising new area of research [3]. The SHB group has previously demonstrated the technique with a helium cooled crystal, achieving a fractional frequency stability of 1.7×10^{-15} at 1 s [4]. We now seek to improve the performance on two fronts: firstly, by exploring a novel multi-spectral-hole probing technique, and secondly, by moving to dilution temperatures (< 1 K) to reduce the influence of temperature fluctuations on spectral-hole frequency stability.

II. METHODS/RESULTS

The concept of the experiment is to use a transmissive spectral line (spectral hole) which has been pumped from a previously absorptive state (burned) in rare-earth ions doped in a crystal. $\text{Eu}^{3+}:\text{Y}_2\text{SiO}_5$ was selected for the longevity of

This project is funded by Ville de Paris Emergence Programme, Agence Nationale de la Recherche, LABEX FIRST-TF (ANR-10-LABX-48-01); H2020 Excellent Science (EMPIR 20FUN08 NEXTLASERS - EMPIR programme cofinanced by the Participating States and from the EU Horizon 2020 Research and Innovation Programme).

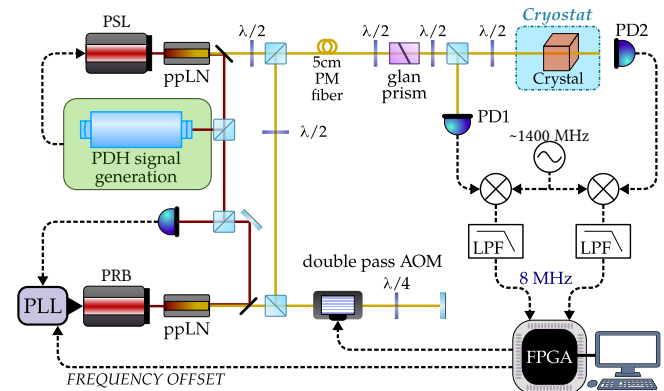

Fig. 1. Illustration of the laser frequency stabilization via SHB setup at SYRTE. Description in text.

the burned hole at cryogenic temperatures, as well as the resulting narrow transmission linewidth (as low as 122 Hz) [5] [6] [7]. The total absorption spectrum of the ion-doped crystal is naturally inhomogeneously broadened by variances in individual ion doping sites producing an absorption linewidth of 2 GHz centered around 580.039 nm, providing the wide band within which to burn spectral holes.

The setup, illustrated in Fig. 1, makes use of two $\lambda = 1160$ nm (infrared) lasers fiber coupled to frequency doubling ppLN waveguides, where the infrared and 580 nm (yellow) components are separated by dichroic mirrors. The initial stage of the stabilization references a probe (PRB) laser's infrared light to a cavity-referenced Pre-Stabilized Laser (PSL). This is accomplished by phase-locking the PRB to the PSL at a frequency offset, f_{PLL} , sourced by an FPGA based software defined radio (SDR) system (Ettus USRP X310) upmixed by a function generator. This beatnote is nominally set at $\Omega_{PLL} = 700$ MHz (producing a beat at 1.4 GHz in yellow) to keep the yellow PSL light outside of the broadened absorption band while tuning the PRB to its center.

The yellow PRB light is sent through an AOM in a double-pass configuration, where the light is frequency

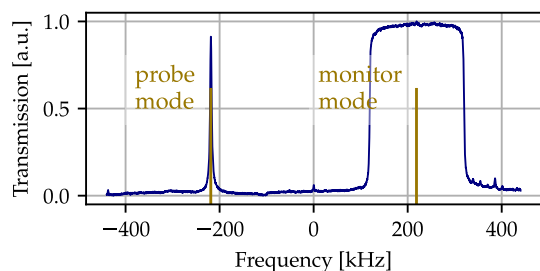

Fig. 2. Measured transmission spectrum of crystal showing a narrow hole as frequency reference and a broad hole to transmit a monitor beam.

shifted by a custom spectrum, also generated by the SDR at a second output. The resulting spectrum of beat notes is split, a reference signal is measured by photodetector PD1, and the other path is sent through the crystal, picking up a phase delay, $\Delta\phi_p$, proportional to the difference frequency between the laser and crystal spectral lines. Photodetector PD2 measures the transmission through the crystal. The beat notes from PD1 and PD2 are digitized by the Ettus where we produce the error signal, $\epsilon = \phi_p^{PD2} - \phi_p^{PD1}$, proportional to the frequency error between the crystal spectral hole and PRB. This correction is applied to the PLL offset, Ω_{PLL} , to actuate the PRB frequency to the center frequency of the spectral hole.

In 2020, the group achieved a fractional frequency stability 1.7×10^{-15} at 1 s while demonstrating a double heterodyne detection method. In this method we burned two spectral holes: one narrow hole as a frequency reference and one broad hole to allow a ‘monitor’ beam to pass without collecting additional phase from the crystal. To measure these we drove the AOM with two frequency components: probe (f_p) and monitor (f_m). This configuration is illustrated in Fig. 2. Using a monitor beam which shares an optical path with the probe allows us to form an error signal with significant common mode noise rejection:

$\epsilon = (\phi_p^{PD2} - \phi_p^{PD1}) - (\phi_m^{PD2} - \phi_m^{PD1})$. In this configuration a fractional frequency equivalent sensing noise at 1 s was measured to be 4×10^{-16} [4].

The conclusion of [4] was the advancement the experiment needs to follow two paths: first, the reduction of detection noise and second, the stabilization of the spectral hole center frequency. We are currently working to achieve these goals through the expansion of the sensing scheme to the simultaneous probing of multiple spectral holes. This will reduce sensing noise by increasing total detection optical power while not increasing the optical power per hole (limited by the danger of broadening the spectral holes). Furthermore, this can effectively improve the stability of the detected spectral hole center frequencies by averaging over several spectral holes. This method will be implemented by burning a broad spectral hole to allow a monitor beam to pass, and burning several narrow holes to allow multiple probe beams in the crystal. The multiple probe beams will be applied by driving the AOM with a signal generated by the

SDR containing the desired frequency components.

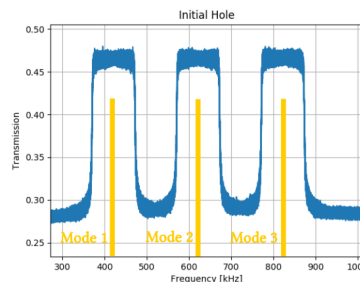

Fig. 3. Measured crystal transmission spectrum used in a sensing noise test for a three-mode detection scheme.

Initial characterizations this new scheme include a measurement of the sensing noise. This was realized by burning three broad spectral holes (effectively three monitor holes) and probing with three modes (illustrated in Fig. 3). We measured the resulting phase noise and scaled this by the typical frequency discriminator of a spectral hole ($180 \mu\text{rad}/\text{Hz}$). The resulting fractional frequency equivalent sensing noise was measured to be 2×10^{-16} at 1 s, a factor of two improvement by adding a single additional detection beat frequency.

III. DISCUSSION AND CONCLUSION

The exciting results of this early work confirm our path forward in the development of this novel multi-mode sensing scheme. To push to a higher number of frequency modes, we require a large bandwidth AOM to apply the complicated RF spectral pattern with a high fidelity. The next steps in this work will be to install and verify this optical subsystem and make new sensing noise measurements while increasing the number of frequency modes.

When this is verified, we will reassemble a complete optical layout while a new dilution stage is install for the cryostat. This new cooler will allow us to achieve sub Kelvin temperatures, exploiting the strong inverse relationship (T^{-4}) between temperature and spectral hole stability. When both systems are completed, we will characterize the new detection scheme in the ultra-low temperature environment, optimizing the inevitable compromise between increased heating against reduced sensing noise in multi-hole probing. The resulting system promises to be a significant advancement in this novel laser frequency stabilization field of spectral hole burning.

REFERENCES

- [1] S. Häfner, S. Falke, C. Grebing, S. Vogt, T. Legero, M. Merimaa, C. Lisdat, and U. Sterr, “ 8×10^{-17} fractional laser frequency instability with a long room-temperature cavity,” *Opt. Lett.*, vol. 40, no. 9, pp. 2112–2115, May 2015.
- [2] D. G. Matei, T. Legero, S. Häfner, C. Grebing, R. Weyrich, W. Zhang, L. Sonderhouse, J. M. Robinson, J. Ye, F. Riehle, and U. Sterr, “ $1.5 \mu\text{m}$ lasers with sub-10 mhz linewidth,” *Phys. Rev. Lett.*, vol. 118, p. 263202, Jun 2017.
- [3] S. Cook, T. Rosenband, and D. R. Leibbrandt, “Laser-frequency stabilization based on steady-state spectral-hole burning in $\text{Eu}^{3+}:\text{Y}_2\text{SiO}_5$,” *Phys. Rev. Lett.*, vol. 114, p. 253902, Jun 2015.

- [4] N. Galland, N. Lučić, S. Zhang, H. Alvarez-Martinez, R. L. Targat, A. Ferrier, P. Goldner, B. Fang, S. Seidelin, and Y. L. Coq, "Double-heterodyne probing for an ultra-stable laser based on spectral hole burning in a rare-earth-doped crystal," *Opt. Lett.*, vol. 45, no. 7, pp. 1930–1933, Apr 2020.
- [5] R. W. Equall, Y. Sun, R. L. Cone, and R. M. Macfarlane, "Ultraslow optical dephasing in $\text{Eu}^{3+}:\text{Y}_2\text{SiO}_5$," *Phys. Rev. Lett.*, vol. 72, pp. 2179–2182, Apr 1994.
- [6] Q.-F. Chen, A. Troshyn, I. Ernsting, S. Kayser, S. Vasilyev, A. Nevsky, and S. Schiller, "Spectrally narrow, long-term stable optical frequency reference based on a $\text{Eu}^{3+}:\text{Y}_2\text{SiO}_5$ crystal at cryogenic temperature," *Phys. Rev. Lett.*, vol. 107, p. 223202, Nov 2011.
- [7] R. Oswald, M. G. Hansen, E. Wiens, A. Y. Nevsky, and S. Schiller, "Characteristics of long-lived persistent spectral holes in $\text{Eu}^{3+}:\text{Y}_2\text{SiO}_5$ at 1.2 k," *Phys. Rev. A*, vol. 98, p. 062516, Dec 2018.