



**HAL**  
open science

## The MICADO first light imager for the ELT: overview of the SCAO module at its final design

Yann Clénet, Tristan Buey, Eric Gendron, Sonia Karkar, Fabrice Vidal, Mathieu Cohen, Frédéric Chapron, Arnaud Sevin, Simone Thijs, Sylvestre Taburet, et al.

### ► To cite this version:

Yann Clénet, Tristan Buey, Eric Gendron, Sonia Karkar, Fabrice Vidal, et al.. The MICADO first light imager for the ELT: overview of the SCAO module at its final design. SPIE Astronomical Telescopes + Instrumentation 2022, Adaptive Optics Systems VIII, SPIE proceedings, 12185, pp.121854S, 2022, 10.1117/12.2629856 . obspm-04009832

**HAL Id: obspm-04009832**

**<https://hal-obspm.ccsd.cnrs.fr/obspm-04009832v1>**

Submitted on 1 Dec 2023

**HAL** is a multi-disciplinary open access archive for the deposit and dissemination of scientific research documents, whether they are published or not. The documents may come from teaching and research institutions in France or abroad, or from public or private research centers.

L'archive ouverte pluridisciplinaire **HAL**, est destinée au dépôt et à la diffusion de documents scientifiques de niveau recherche, publiés ou non, émanant des établissements d'enseignement et de recherche français ou étrangers, des laboratoires publics ou privés.

# PROCEEDINGS OF SPIE

[SPIDigitalLibrary.org/conference-proceedings-of-spie](https://SPIDigitalLibrary.org/conference-proceedings-of-spie)

## The MICADO first light imager for the ELT: overview of the SCAO module at its final design

Yann Clénet, Tristan Buey, Eric Gendron, Sonia Karkar, Fabrice Vidal, et al.

Yann Clénet, Tristan Buey, Eric Gendron, Sonia Karkar, Fabrice Vidal, Mathieu Cohen, Frédéric Chapron, Arnaud Sevin, Simone Thijs, Sylvestre Taburet, Bruno Borgo, Jean-Michel Huet, Alexandre Blin, Olivier Dupuis, Julien Gaudemard, Florian Ferreira, Jordan Raffard, Fanny Chemla, Vincent Lapeyrère, Vincent Deo, Arielle Bertrou-Cantou, Nicolas Galland, Sylvain Guieu, Eric Meyer, Nicolas Gautherot, Emmanuel Tisserand, Hervé Locatelli, François Meyer, Amal Zidi, Caroline Kulcsár, Henri-François Raynaud, Benoit Sassolas, Laurent Pinard, Christophe Michel, Damien Gratadour, Bertrand Le Ruyet, Roderick Dembet, Manuel Ortiz, Claude Collin, Vartan Arslanyan, Bosko Doncic, Lahoucine Ghouchou, Issan Ibn Taïeb, Pierre Baudoz, Elsa Huby, Gérard Rousset, Sebastian Rabien, Veronika Hörmann, Eckhard Sturm, Richard Davies, "The MICADO first light imager for the ELT: overview of the SCAO module at its final design," Proc. SPIE 12185, Adaptive Optics Systems VIII, 121854S (29 August 2022); doi: 10.1117/12.2629856

**SPIE.**

Event: SPIE Astronomical Telescopes + Instrumentation, 2022, Montréal, Québec, Canada

# The MICADO first light imager for the ELT: overview of the SCAO module at its final design

Yann Clénet<sup>a</sup>, Tristan Buey<sup>a</sup>, Eric Gendron<sup>a</sup>, Sonia Karkar<sup>a</sup>, Fabrice Vidal<sup>a</sup>, Mathieu Cohen<sup>b</sup>, Frédéric Chapron<sup>a</sup>, Arnaud Sevin<sup>a</sup>, Simone Thijs<sup>a</sup>, Sylvestre Taburet<sup>b</sup>, Bruno Borgo<sup>a</sup>, Jean-Michel Huet<sup>b</sup>, Alexandre Blin<sup>c</sup>, Olivier Dupuis<sup>a</sup>, Julien Gaudemard<sup>b</sup>, Florian Ferreira<sup>a</sup>, Jordan Raffard<sup>a</sup>, Fanny Chemla<sup>b</sup>, Vincent Lapeyrère<sup>a</sup>, Vincent Deo<sup>a</sup>, Arielle Bertrou-Cantou<sup>a</sup>, Nicolas Galland<sup>a</sup>, Sylvain Guieu<sup>d</sup>, Eric Meyer<sup>e</sup>, Nicolas Gautherot<sup>e</sup>, Emmanuel Tisserand<sup>e</sup>, Hervé Locatelli<sup>e</sup>, François Meyer<sup>e</sup>, Amal Zidi<sup>a,f</sup>, Caroline Kulcsár<sup>f</sup>, Henri-François Raynaud<sup>f</sup>, Benoit Sassolas<sup>g</sup>, Laurent Pinard<sup>g</sup>, Christophe Michel<sup>g</sup>, Damien Gratadour<sup>a</sup>, Bertrand Le Ruyet<sup>a</sup>, Roderick Dembet<sup>a</sup>, Manuel Ortiz<sup>a</sup>, Claude Collin<sup>a</sup>, Vartan Arslanyan<sup>a</sup>, Bosko Doncic<sup>a</sup>, Lahoucine Ghouchou<sup>a</sup>, Issan Ibn Taïeb<sup>a</sup>, Pierre Baudoz<sup>a</sup>, Elsa Huby<sup>a</sup>, Gérard Rousset<sup>a</sup>, Sebastian Rabien<sup>h</sup>, Veronika Hörmann<sup>h</sup>, Eckhard Sturm<sup>h</sup>, and Richard Davies<sup>h</sup>

<sup>a</sup>LESIA, Observatoire de Paris, Université PSL, CNRS, Sorbonne Université, Université de Paris Cité

<sup>b</sup>GEPI, Observatoire de Paris, Université PSL, CNRS

<sup>c</sup>DT-INSU

<sup>d</sup>EFISOFT

<sup>e</sup>Institut UTINAM, Université Bourgogne Franche Comté, OSU THETA

<sup>f</sup>LCF, IOGS, CNRS, Université Paris Saclay

<sup>g</sup>LMA, IP2I Lyon, CNRS, Université de Lyon, Université Claude Bernard Lyon 1

<sup>h</sup>MPE

## ABSTRACT

MICADO is the ELT first light instrument, an imager working at the diffraction limit of the telescope thanks to two adaptive optics (AO) modes: a single conjugate one (SCAO), available at the instrument first light and developed by the MICADO consortium, and a multi conjugate one (MCAO), developed by the MORFEO consortium.

This contribution presents an overview of the SCAO module while MICADO and its SCAO are in the last phase of their final design review. We focus on the SCAO architecture choices and present the final design of the SCAO subsystems: the Green Doughnut structure, the SCAO wavefront sensor, the SCAO calibration unit, the SCAO ICS (i.e. AOCS) and the SCAO RTC. We also present the SCAO global performance in terms of AO correction, obtained from an error budget that includes contributors estimated from AO end-to-end simulations as well as instrumental contributors. Finally, we present the current SCAO subsystems prototyping and the main milestones of the SCAO AIT plan.

**Keywords:** ELT, MICADO, SCAO, final design, prototyping, AIT

## 1. INTRODUCTION: MICADO OVERVIEW

The MICADO imager is the ELT first light instrument.<sup>1</sup> Working in the near-IR (0.8-2.4  $\mu\text{m}$ ) at the ELT diffraction limit, it will offer four observing modes:

- Standard imaging: with 1.5 & 4 mas pixel scales, the corresponding FoV will be 19 & 51 arcsecond<sup>2</sup>. More than 30 broad-band & narrow-band filters will be available.

---

Further author information: send correspondence to Y. Clénet, e-mail: yann.clenet "at" obspm.fr

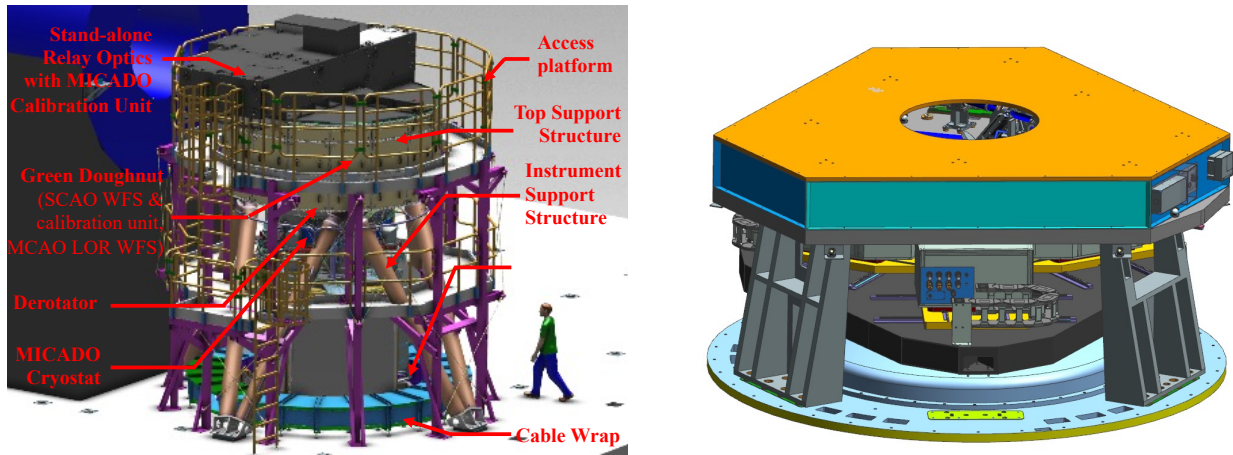

Figure 1. Left: MICADO at the telescope in its standalone configuration, i.e. with the SCAO module alone and a dedicated optical relay. Right: The Green Doughnut with the baffled SCAO parts on the top and the MORFEO MCAO LOR WFS at the bottom.

- Astrometric imaging: it drives MICADO design, with a gravity invariant implementation, a fixed mirror optical design, state-of-the-art ADC and dedicated astrometric calibration and data pipeline.
- High contrast imaging:<sup>2,3</sup> it will use the central detector and will be enabled via a classical configuration of focal plane coronagraphs and Lyot stops, as well as pupil plane vAPP coronagraphs and sparse aperture masking. Pupil tracking will be available for angular differential imaging.
- Slit spectroscopy: it will provide coverage of a wide wavelength range simultaneously (J: 1.16-1.35  $\mu\text{m}$ , HK: 1.49-2.45  $\mu\text{m}$  or IzJ: 0.82-1.55  $\mu\text{m}$ ) at a resolution of 20000 on faint compact or unresolved sources. Three slits will be available: 3'' $\times$ 16 mas (IzJ), 15'' $\times$ 20 mas (J & HK), 3'' $\times$ 48 mas (IzJ & HK).

The SCAO correction, available at first light, is developed by MICADO (Fig. 1 left). The MCAO correction, developed by the MORFEO (previously named MAORY) consortium,<sup>4</sup> will be available few years after MICADO first light.

MICADO current planning is the following:

- 11/2018: PDR
- 04/2021 - now: FDR sessions
- 06/2027: PAE
- Late 2027: @Armazones

## 2. MICADO SCAO FINAL DESIGN

### 2.1 SCAO GD structure and dichroic plate

The Green Doughnut (GD) is a volume hosting in its upper part the SCAO module and in its lower part the MORFEO MCAO LOR WFS (Fig. 1 right). The SCAO GD structure is made of 1) the optical bench supporting the SCAO WFS and the SCAO calibration unit, 2) its feet connecting the bench to the MICADO cryostat interface and 3) below the bench, the SCAO dichroic plate assembly.

The SCAO GD structure has stringent specifications:

- SCAO envelop limited to 2.8m $\times$ 0.4m
- Mass budget limited to 700 kg
- First eigen frequency greater than 55 Hz

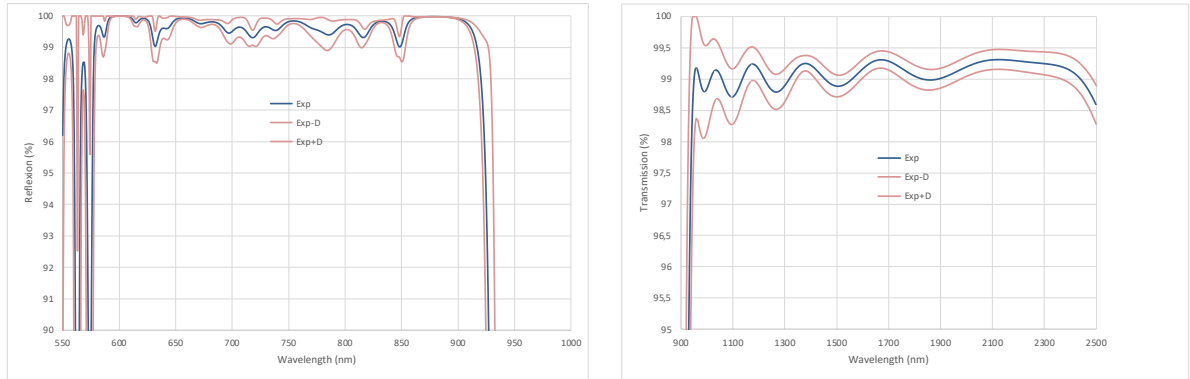

Figure 2. Reflexion (left) & transmission (right) profiles of the dichroic coating from Monte Carlo study (Exp: mean value curve, Exp $\pm$ D: envelopes of all curves considering a  $3\sigma$  deviation).

- Low CTE to ensure optical alignment over the ESO-specified environmental conditions
- Survival to earthquake following ESO specifications

These specifications are fulfilled thanks to 1) a CFRP-Al honeycomb bench, with a baffling and pods contributing to the structural stability, 2) CFRP feet. The SCAO bench cover is in three pieces to allow its dismounting and the access to the SCAO parts for maintenance.

The SCAO dichroic plate is removable for MCAO operations. Its tilt ( $18.15^\circ$ ) allows to escape the MCAO LOR patrol FoV with an acceptable vignetting while keeping limited the induced astigmatism (110 nm rms). This  $\varnothing 305\text{mm} \times 30\text{mm}$  CaF<sub>2</sub> dichroic plate has a  $0.026^\circ$  wedge on its rear surface to compensate for the lateral shift of the pupil that it introduces at the entrance of the cryostat. The designed coating allows a 92% reflexion in average over the [589 – 960] nm WFS bandpass and at the same time a 97% transmission over the [960 – 2450] nm scientific bandpass (Fig. 2).

## 2.2 SCAO WFS

The SCAO WFS (Fig. 3) is based on a double pyramid WFS. It is sensing the wave-front between 0.589 and 0.96  $\mu\text{m}$  with a  $\varnothing 2''$  FoV. Critical functionalities of the WFS are: pupil control & guiding, field patrolling, compensating for atmospheric dispersion, managing NCPA, wave-front sensing itself.

Pupil guiding is handled thanks to a pupil imaging lens system (for small pupil offsets), a pupil steering mirror at the entrance of the WFS (for large and rare pupil offsets), a K-mirror (for rotational offsets).

A field selector at the entrance of the WFS allows to select, finely position and track the target in the SCAO  $6'' \times 20''$  patrol FoV, to correct for the differential image position between IR and visible, to manage dithering and offsets.

At an intermediate pupil plane are located a phase plate assembly for the fixed-NCPA compensation, an ADC made of two rotating prisms, a neutral density positioner, the modulation mirror specified at  $\pm 0.1$  mrad @ 500 Hz and 1 mrad @ 50 Hz.

The sensing is performed thanks to an achromatic  $20\text{mm} \times 20\text{mm} \times 39\text{mm}$  double pyramid in a F/30 beam, manufactured by WZW, and the ESO in-development ALICE camera based on the E2V CCD220 detector with  $240 \times 240$  pixels.

The WFS also integrates a pupil viewing camera, sampling finely the pupil for AIT & maintenance, and calibration sources (e.g., for reference slopes) at the WFS entrance.

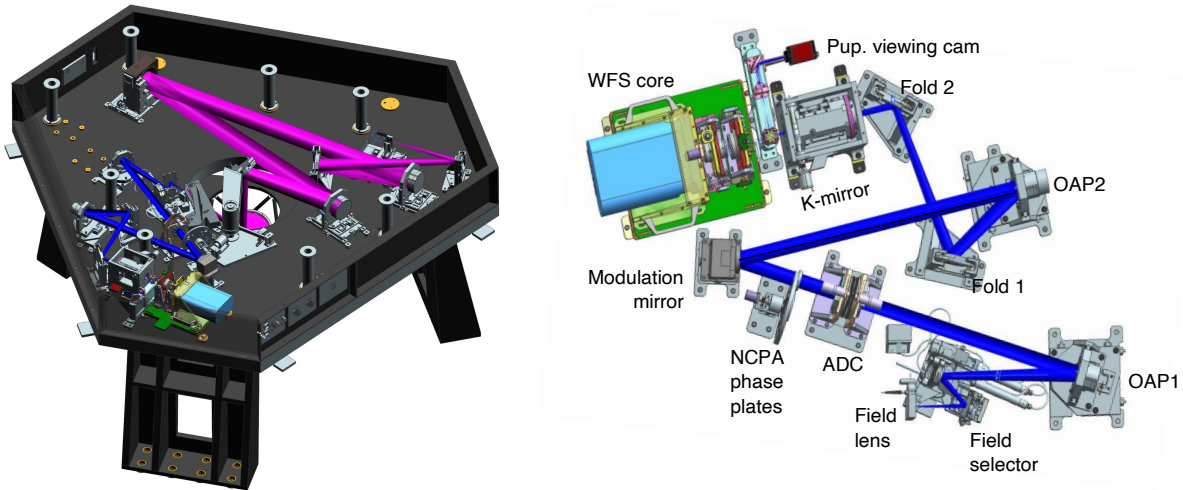

Figure 3. Left: Opto-mechanical design of the WFS (blue beam) and SCU (magenta beam) in its final on-sky configuration. Right: Zoom on the WFS components design.

### 2.3 SCAO calibration unit

The SCAO calibration unit (SCU) is the SCAO test, calibration and maintenance facility. During its lifetime it will know successively an AIT and an on-sky configuration.

The SCU AIT configuration (Fig. 4) will be used during the AIT phases in Meudon and in Garching. It will allow to perform the integration and performance tests of the SCAO module. For this purpose, it will be equipped with a recently developed ALPAO 64×64 actuator deformable mirror (DM) used for the validation of the SCAO performance, a slow tip-tilt mirror (TTM) allowing with the 64×64 DM to mimic the M4+M5 configuration, turbulent phase screens, pupil masks and calibration/alignment sources.

SCU will be turned into its final on-sky configuration (Fig. 3 left) during AIT in Garching, removing the turbulent phase screens, the pupil masks and the TTM, and replacing the 64×64 DM by an ALPAO DMX37 low order DM (so-called XDM), dedicated to NCPA calibration.

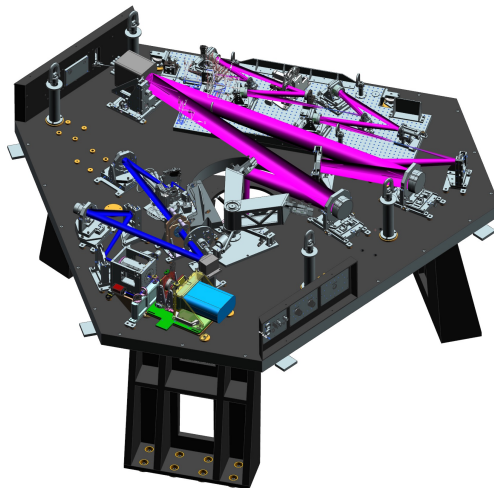

Figure 4. The SCU in AIT configuration, with a breadboard supporting the AIT components (so-called SCU AIT module).

## 2.4 SCAO real-time computer

SCAO RTC design<sup>5</sup> is based on the COSMIC platform, developed by Observatoire de Paris and ANU, and the RTC Toolkit, developed by ESO.

SCAO RTC will follow the functional architecture defined by ESO, with the Hard Real-Time Core (HRTC), the Soft Real-Time Cluster (SRTC) and the Communication Infrastructure, and with an additional simulator (SIM) module.

Considering an MVM implementation at 500 Hz with 24k measurements and 5.4k commands, the latency goal of 140  $\mu$ s left for computation leads to a required 3.3 TB/s memory bandwidth in single precision for the HRTC. On the SRTC side, the required compute throughput for the supervisor, related to the various calibration and optimization data tasks, is about 400 GFLOP.

The HRTC hardware (Fig. ?? left) is composed of a single node, based on 3 NVIDIA A100 GPU boards in the Dell PowerEdge R7525 server, which receives WFS frames from the RTC Communication Infrastructure and publishes real-time telemetry through the same infrastructure. Efficient data streaming between the GPU and the network controller is provided by standard NIC with DPDK support (e.g., Mellanox ConnectX-6 MCX621102AN). The SRTC is split in 4 components: 1) the HRTC gateway, which receives MUDPI real-time telemetry from the HRTC and broadcasts it into DDS topics for other SRTC components, 2) the SRTC gateway, which receives commands from the AOCS, monitors and controls all the SRTC processes and collects metadata for archiving, 3) the storage node and 4) the computation node (making use of 3 NVIDIA A100 boards to run the COMPASS simulator for synthetic interaction matrix generation).

The HRTC software stack (aka OCEAN) is divided in 3 levels (Fig. ?? right): an interface manager (called Octopus), the core real-time pipeline (called Marlin) and the user interface manager (called Kraken). The telemetry middleware is provided by the RTC Toolkit. The SRTC software uses COSMIC logics to evaluate and optimize the HRTC pipeline. This logic is integrated and executed into the RTC Toolkit environment to get access to all services (real-time display, errors, logs, etc).

## 2.5 SCAO ICS

SCAO ICS is based on the ESO instrument control software framework, with the particularity of having no need of Observation Coordination Manager, nor Data Product Manager (SCAO does not take exposures).

While developed by the SCAO team within the MICADO consortium, the SCAO ICS is functionally a part of MORFEO ICS. Though, to keep developments of both consortia as independent as possible, they agreed on a single API (actually Python packages with pre-defined front end functions and function signatures) to handle communications between MICADO and MORFEO (and then SCAO, see Fig. 5).

SCAO ICS is made of 6 hardware nodes (Fig. 6): 1) the instrument workstation, running the ICS software, 2) the XDM gateway workstation, converting the MUDPI ESO standard protocol to valid UDP ALPAO commands, 3) the RTC gateway for SCAO ICS/RTC communications, 4) the SCAO PLC, controlling the SCAO devices, 5) the ALICE workstation, for ALICE control/housekeeping, 6) the pupil viewer camera workstation, controlling and receiving frames from this GigE Vision technical camera.

## 2.6 SCAO global performance estimation

SCAO performance<sup>6</sup> has been estimated with our GPU-based COMPASS platform that allows fine sampling (e.g. 512 $\times$ 512 pixel support for our SCAO final pyramid image) and fast simulation even at the ELT scale. For MICADO FDR, we developed optimizations to deal with pyramid WFS specific calibrations expected at the ELT (optimal modal basis, petalling, optical gains, NCPA management). We then evaluated the impact of the AO loop frequency, RTC latency, and other specific SCAO optimization parameters (modulation amplitude, number of controlled modes, etc) as a function of the reference source magnitude and turbulence conditions. We also evaluated the impact of ELT contributors: M1 reflectivity errors, M1 phase aberrations, M1 missing segments, M4 mis-registrations, telescope windshake and vibrations. The SCAO control is modal-based, using the continuous basis<sup>7</sup> in order to correctly handle petalling. For high-order modes, the CLOSE algorithm<sup>8</sup> is used to measure and compensate for the pyramid optical gains. On low-order modes (tip-tilt as a baseline), a LQG controller with model-based identification is used<sup>9</sup> (Fig. 7).

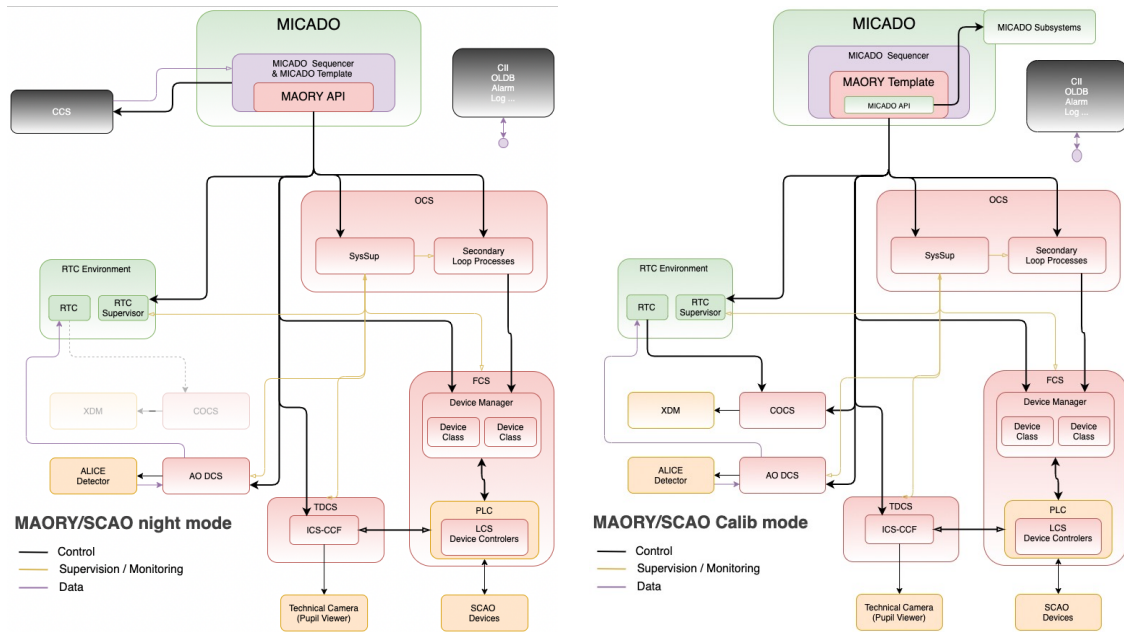

Figure 5. SCAO ICS software architecture overview. Left: elements and communication used for on-sky operation (night mode with AO). Right: elements and communication used for SCAO calibration using MICADO images. MOR-FEO/SCAO templates are running inside the MICADO sequencer. It will however access MICADO functionality through the MICADO API

The global SCAO error budget, accounting for AO simulation error as well as instrumental terms, leads to a global performance of  $SR(K)=66\%$ , fulfilling the 60% SR specification (Fig. 8). Accounting for windshake and

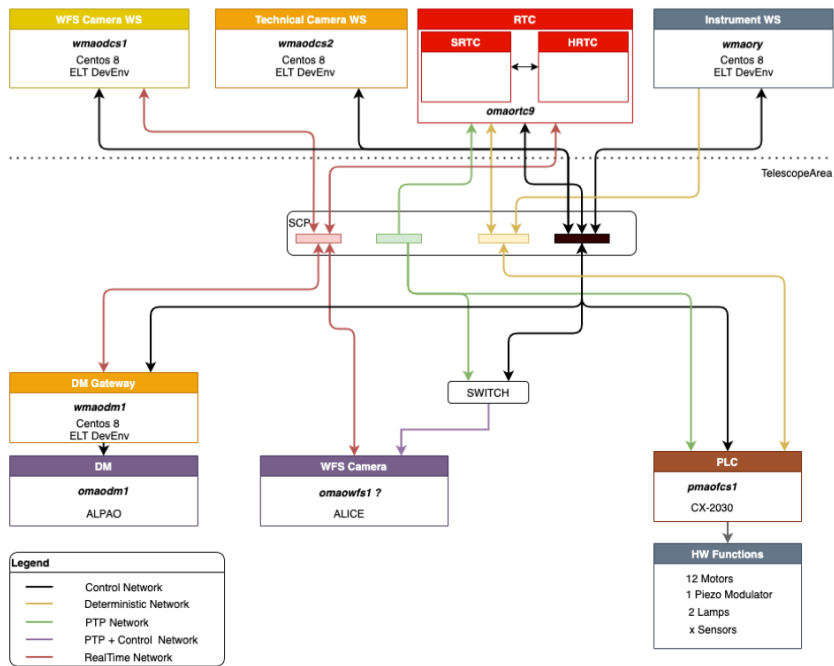

Figure 6. SCAO ICS hardware architecture overview.



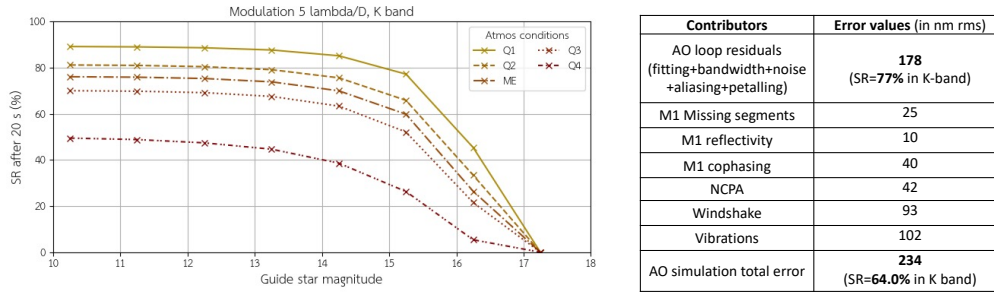

Figure 7. Left: AO simulation based on-axis performance, as a function of reference source magnitude and for different turbulence conditions. Right: SCAO error budget for AO simulation terms, under median atmospheric conditions, at 30° zenith angle, with a 500 Hz loop frequency and a reference source magnitude of 10.

rather strong vibrations (total amplitude of 42 nm rms split over resonant frequencies at 20, 60 and 200 Hz), performance is SR (K)=56%, a bit below specification.

### 3. MICADO SCAO PROTOTYPING

#### 3.1 WFS prototyping

Our development plan includes prototyping of several WFS subsystems. Latest prototyping are concerning the so-called WFS core and the field selector.

The WFS core prototype is made of an OCAM2 camera, a double pyramid prism (similar to or the final one) and its mount, the pupil imaging lenses (off-the-shelf ones, not the final ones) and their mount. The OCAM2 and the pyramid have been ordered and delivered (Fig. 9 extreme left). The prism mount design is being slightly adjusted after first mounting tests (Fig. 9 middle left). The PIL mount is being redesigned, using PI L-505 linear stages to handle both large displacements (for adjustments) and small displacements (during observations) of the optics.

The field selector design is following a proto-flight strategy, adapting the design while testing it. Its design principle is based on 2 parallel plane mirrors, that have 3 motorised degrees of freedom: two rotations (around

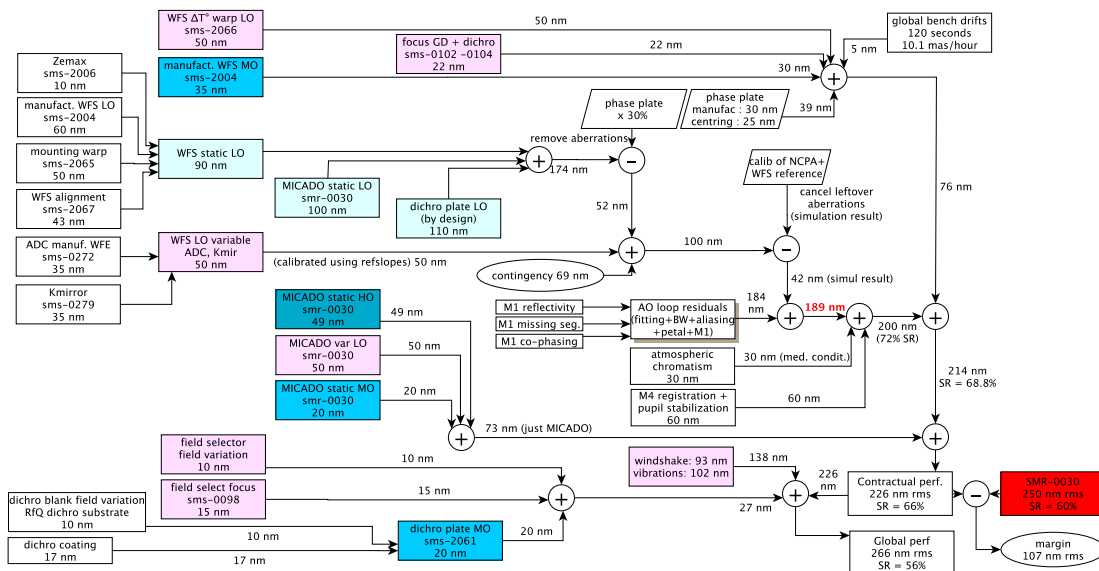

Figure 8. Global SCAO error budget.

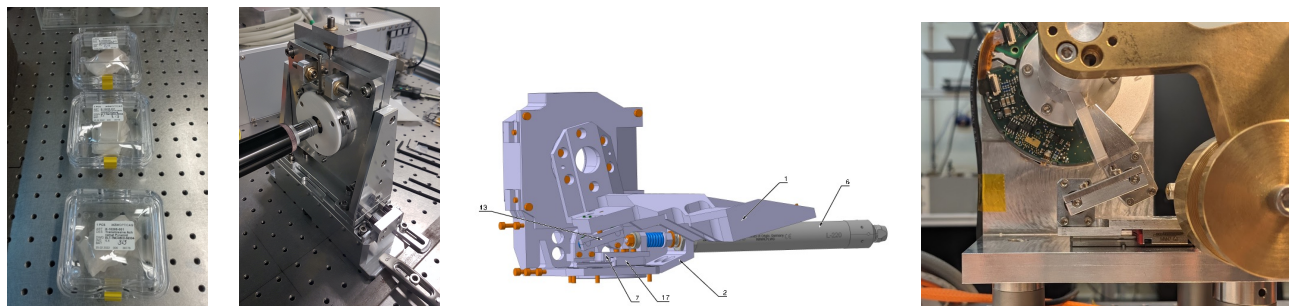

Figure 9. WFS prototyping. From left to right: WZW pyramid prisms after their delivery, pyramid mount, final design of the tested altitude rotation, prototype of the altitude rotation.

a vertical and horizontal axis, as an alt-az mount) and an adjustable distance between the mirrors. A prototype of the most critical rotation system (the altitude one) has been built, using the same actuator (PI L220) and the same axes with angular sensor (PI MRP5010) as in the design (Fig. 9 middle right & extreme right). The moving mass is preproduced. First tests results were out of specifications, leading us to modify in particular how the motor movements are transmitted to the mirrors, so that now we are in specification (Fig. 10).

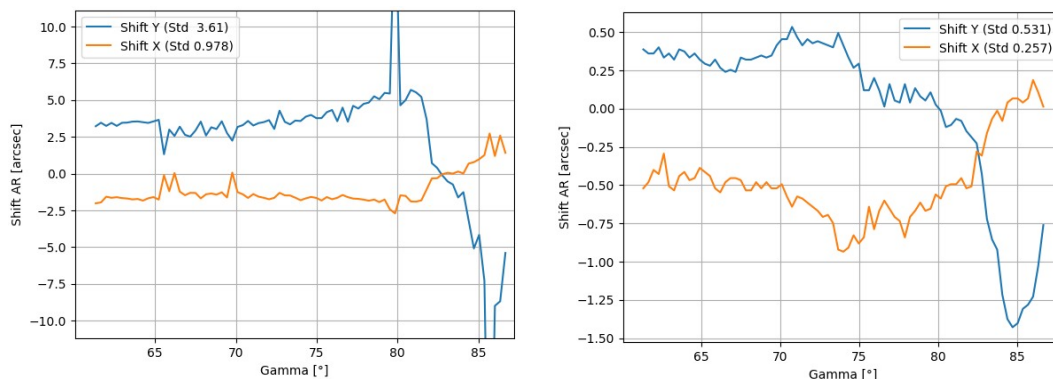

Figure 10. Test results, showing the shifts (X/Y) in position of an image at a given rotation angle ( $\gamma$  [°]) between the upward and the downward displacements. Left: before design modification (out of spec). Right: after design modification (in spec). Max amplitude during the rotation shall be less than 1.5'' up to  $\gamma \approx 80^\circ$ .

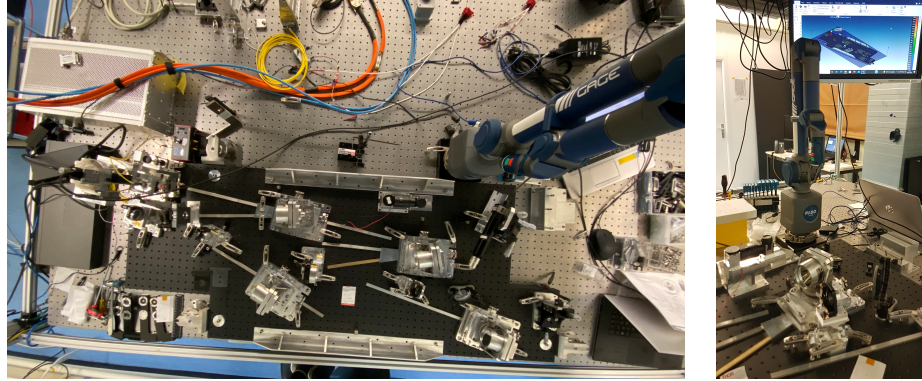

Figure 11. Left: the SCU AIT module. Right: the Faro arm

### 3.2 SCU prototyping

SCU prototyping is mainly related to the alignment strategy that has been set up because of the SCAO bench material, carbon fiber reinforced plastic (CFRP). On the contrary to a classical aluminium bench, the SCAO subsystems supports in interface to the bench cannot be adjusted in position, leaving the degrees of freedom of the optics in their support as the only, limited, adjustment for alignment.

We checked and validated the feasibility of this alignment with the SCU AIT module (see Sect. 2.3) and using a Faro arm (Fig. 11).

### 3.3 SCAO prototyping

At the end of 2022, when the full WFS core is ready, it will be assembled together with the SCU AIT module, the ALPAO high order DM, the RTC prototype and custom electronics boards driving the modulation mirror. It will allow the first SCAO loop under broadband illumination with final parts of the SCAO. This so-called flat conf beta (Fig. 12) aims at checking the proper functioning of the WFS hardware and at testing with hardware the HRTC and SRTC algorithms (optimized modal gains, NCPA & petalling management, etc).

## 4. MICADO SCAO MAIT PLAN

### 4.1 AIT in Observatoire de Paris

This first AIT period concerns the SCAO sub-systems integration and SCAO system verification at Observatoire de Paris. At the end, SCAO system validation tests will be achieved before delivery to Garching. The main

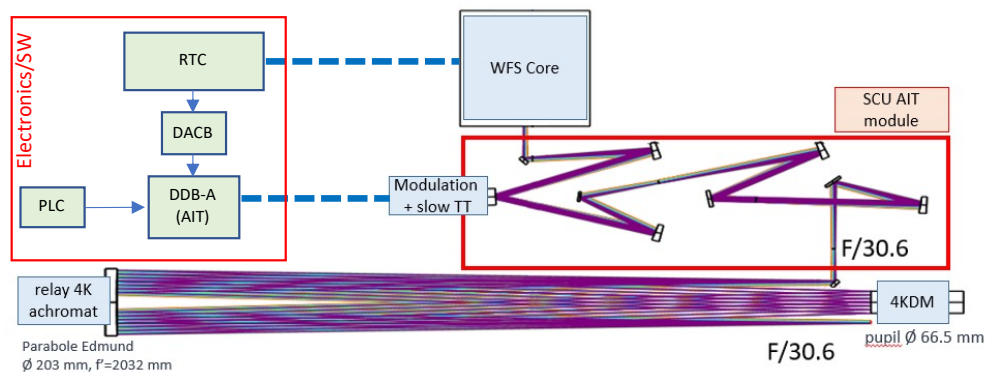

Figure 12. The SCAO prototype in flat conf beta.

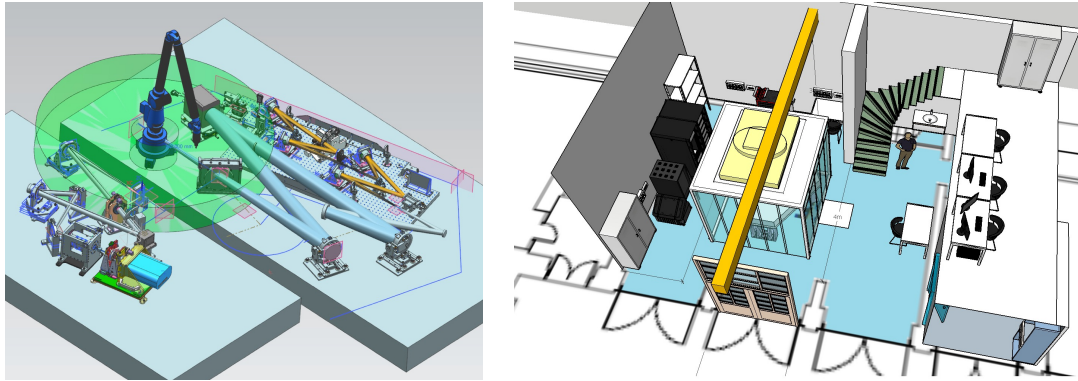

Figure 13. Left: The SCAO flat configuration at LESIA lab. Right: The final integration hall at Observatoire de Paris during the GDS configuration. SCAO is under a mobile clean booth with laminar flow.

objectives are: sub-systems unitary validation tests, SCAO internal interfaces verification, functionalities verification including possible observing modes, AO loop verification and performance measurements using a test IR camera, RTC/ICS software verification.

This period at LESIA-Observatoire de Paris is divided in three phases:

- Unitary validation test phase of the components of each SCAO sub-system (e.g. test of the ADC before optical alignment of the WFS).
- Flat configuration phase, at LESIA (Fig. 13 left): it starts with a subsystems validation phase (each sub-system is fully integrated and interfaces with other sub-systems are validated), followed by a validation phase. WFS and SCU are optically aligned on dedicated standard benches (flat) and optically interfaced. Elements that will be out of that plane in the final configuration are not integrated here. ICS and RTC software are deployed and tested. Global performance measurements in closed loop are achieved using the (nearly) complete SCAO system.
- GDS configuration phase in the final integration hall (Fig. 13 right): SCAO is integrated and validated in the same AIT configuration as the one delivered to Garching. First, WFS and SCU elements of the flat configuration are integrated on the final CFRP bench, as well as the field selector, the alignment mirror Mpup, the dichroic assembly, the SCU mirror deployment system, connection panels and internal cabling. The two SCU configurations will be integrated: AIT and on-sky. SCAO performance in close loop is done with the complete SCAO system.

At the end of the performance tests in the GDS configuration (in SCU AIT and on-sky configurations, with the ALPAO high order DM and with the XDM) we will perform a complete rehearsal of unmounting, packing, unpacking, reintegration, realignment and performance test with XDM, as it will be done in the IAA integration hall at the telescope. Once validated, everything is packed again for transport to Garching.

## 4.2 AIT in Garching

In Garching, the interfaces and performance with MICADO will have to be checked and tested. AIT activities will begin with go-no-go tests and SCAO AIT on-the-ground functional tests before mounting SCAO on MICADO cryostat. Then will come the mechanical, optical, software and electrical integration of SCAO with MICADO.

A first important step will be the measurement with MICADO of the NCPA and the ordering/delivery of the NCPA phase plates to be afterwards integrated in the WFS path. A second important test will then consist in a partial PAE for SCAO, with the verification with ESO of the AO loop and performance measurements (including NCPA compensation) in all modes (imaging, coronagraphy, spectroscopy, etc.). The SCU in its AIT configuration, with the ALPAO high order DM, will be used for that purpose (Fig. 14).

In a last step, SCU will be integrated in its final on-sky configuration, to validate it and proceed with the final PAE with MICADO.

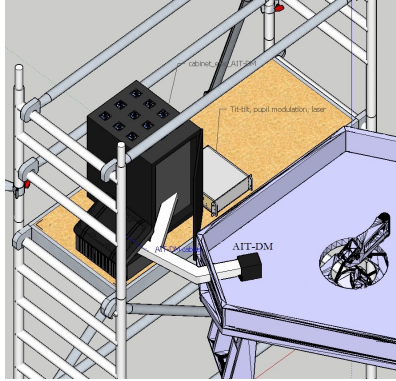

Figure 14. Dedicated scaffolding set up at Garching for the ALPAO high order DM and its electronics.

### 4.3 AIT in Chile before commissioning

SCAO will be delivered in the ELT Entrance Hall and moved to the ELT Instrument Assembly Area (IAA). The SCAO system will be unpacked and assembled on the ground, close to the MICADO cryostat (Fig. 15). SCAO critical components, dismantled for transportation, will be mounted back on the SCAO bench. Cabling will be reinstalled, electronics and mechanisms control will be checked, the internal optical alignment will be verified. The SCAO bench envelop will be then closed.

Then SCAO is moved to the Nasmyth platform for integration on the MICADO cryostat (Fig. 16). The SCAO WFS pupil will be aligned to the MICADO rotation axis, the SCAO WFS patrol field will be aligned and registered to MICADO. Then will start the commissioning activities.

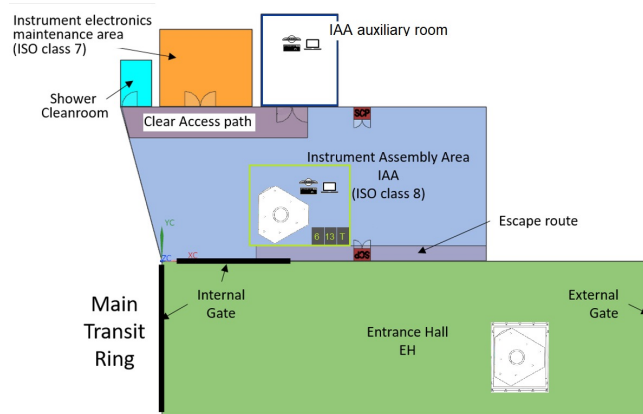

Figure 15. SCAO in the ELT Entrance Hall and then in the ELT Instrument Assembly Area .

## ACKNOWLEDGMENTS

This work has benefited from the support of the French Programme d'Investissement d'Avenir through the project F-CELT ANR-21-ESRE-0008, of the project WOLF ANR-18-CE31-0018, and of the CNRS 80 PRIME program.

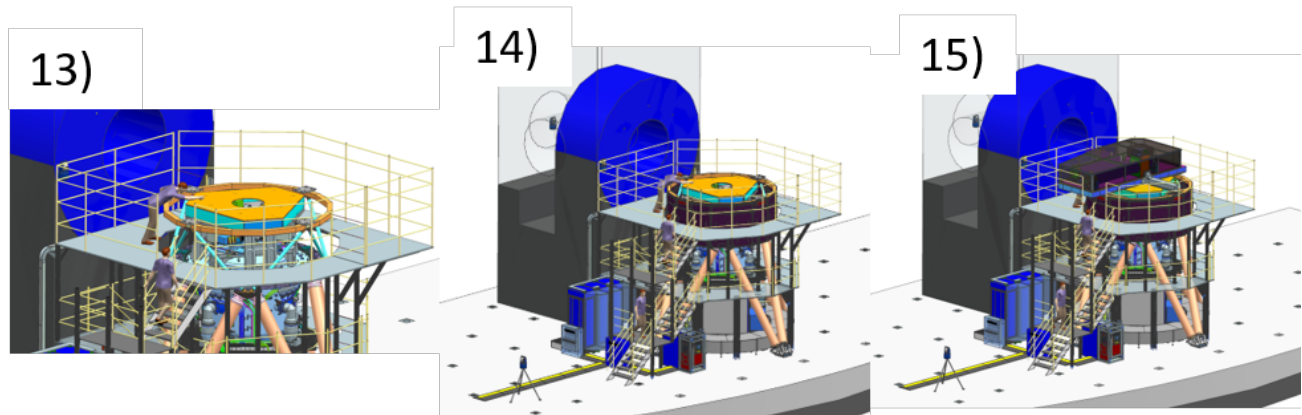

Figure 16. Last phases of the MICADO AIT on the Nasmyth platform, involving SCAO (access platform is being redesigned).

## REFERENCES

- [1] Davies, R., Alves, J., Clénet, Y., et al., “The final design of MICADO, the first light ELT camera,” in [*Ground-based and Airborne Instrumentation for Astronomy IX*], *Proc. SPIE this conference* (2022).
- [2] Baudoz, P., Huby, E., Baran, N., et al., “The MICADO first light imager for the ELT: design and performance of the high contrast mode,” in [*Adaptive Optics Systems VIII*], *Proc. SPIE this conference* (2022).
- [3] Huby, E., Baudoz, P., Clénet, Y., et al., “The MICADO first light imager for the ELT. STARLOC: the star tracking algorithm for the MICADO lyot coronagraphs,” in [*Adaptive Optics Systems VIII*], *Proc. SPIE this conference* (2022).
- [4] Ciliegi, P., Agapito, G., Aliverti, M., et al., “MAORY/MORFEO@ELT: general overview up to the preliminary design and a look towards the final design,” in [*Adaptive Optics Systems VIII*], *Proc. SPIE this conference* (2022).
- [5] Sevin, A., Ferreira, F., Gendron, E., et al., “The MICADO first light imager for the ELT: final design and prototype of the MICADO SCAO RTC,” in [*Adaptive Optics Systems VIII*], *Proc. SPIE this conference* (2022).
- [6] Vidal, F., Galland, N., Bertrou-Cantou, A., et al., “The MICADO first light imager for the ELT: FDR numerical simulations for the SCAO mode,” in [*Adaptive Optics Systems VIII*], *Proc. SPIE this conference* (2022).
- [7] Bertrou-Cantou, A., Gendron, E., Rousset, G., et al., “Confusion in differential piston measurement with the pyramid wavefront sensor,” *A&A* **658**, id. A49 (2022).
- [8] Deo, V., Gendron, E., Vidal, F., et al., “A correlation-locking adaptive filtering technique for minimum variance integral control in adaptive optics,” *A&A* **650**, id. A41 (2021).
- [9] Zidi, A., Raynaud, H.-F., Kulcsár, C., et al., “The MICADO first light imager for the ELT: SCAO LQG control performance with windshake, vibrations and mirror dynamics,” in [*Adaptive Optics Systems VIII*], *Proc. SPIE this conference* (2022).